



English



## **COMPLETE SERVICE**

The strength of Sundplast lies in the fact it is a modern flexible company that can provide its customers with a rapid, comprehensive service. In addition to the manufacturing of furniture fittings, we can also offer a sub-contracting service for plastic parts. With 20 modern injection moulding machines and CNC robots we are able to guarantee good capacity and quick delivery. And our own workshop ensures that the injection moulding tools are carefully maintained.

We make no compromises where the materials we use are concerned. From initial machining right through the production process to packing and delivery, all our products are subjected to quality and environmental controls at every stage. You are kindly invited to discuss your ideas with us!



## **INJECTION MOULDING THAT REQUIRES THAT LITTLE EXTRA**

The interaction between Sundplast's quality assurance system ISO 9002, CAD CAM design, expert staff, modern machinery and traditional craftsmanship means we can also produce complicated products.



## **BESPOKE DESIGN**

AB SUNDPLAST is constantly developing new handles and furniture fittings.

A sound knowledge of the intricacies of design is just as important as a sound knowledge of the intricacies of production. That is why we design the products in our range ourselves, and why we also make our own injection moulding tools, with a view to ensuring top quality production. CAD CAM is used for the design and manufacturing of our own injection moulding tools. We have a wide range of designs. Call us, we may have just the product you're looking for. If not, we can assist with the design, tooling and manufacturing.

## **ENVIRONMENT**

The interaction between Sundplast's environmental management system is a guarantee for that a proper evaluation has been proceed in all stages of products. Sundplast is certified according to the environmental system ISO 14001



### **CENTRALLY LOCATED SUPPLIER TO THE FURNITURE INDUSTRY**

Sundplast's excellent location in southern Sweden facilitates contact with other EU countries and the rest of Europe. Sundplast specialises in injection moulding of handles, knobs and furniture fittings. Modern technology has presented almost unlimited potential when selecting design, colour and material combination. In addition to an expanding standard range, we also offer total system packages.



---

### **A WIDE RANGE OF STANDARD COLOURS**

Modern technique gives almost unlimited possibilities to choose different shapes, colours and material combinations.



## STANDARD RANGE

0493

VAXHOLM CC 64 MM

VAXHOLM CC 64 MM  
SCREW 3.5 MM SELF-TAPPING  
MATERIAL: PP  
SURFACE: POLISHED

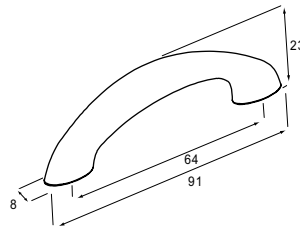

0494

VAXHOLM CC 96 MM

VAXHOLM CC 96 MM  
SCREW 3.5 MM SELF-TAPPING  
MATERIAL: PP  
SURFACE: POLISHED

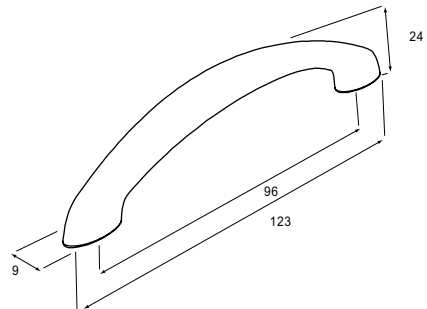

0495

VAXHOLM CC 128 MM

VAXHOLM CC 128 MM  
SCREW 3.5 MM SELF-TAPPING  
MATERIAL: PP  
SURFACE: POLISHED

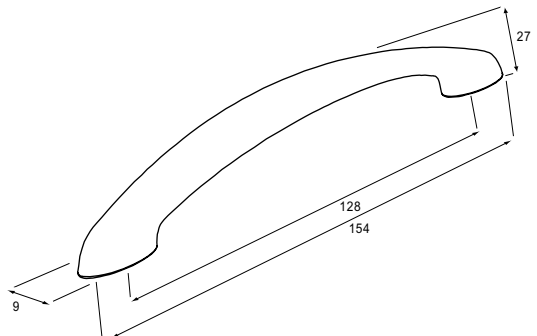

0478

BOW-HANDLE CC 96 MM

BOW-HANDLE CC 96 MM  
SCREW 3.5 MM SELF-TAPPING OR M4  
MATERIAL: PP  
SURFACE: POLISHED

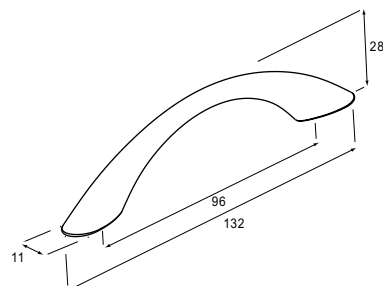

0437

BOW-HANDLE CC 128 MM

BOW-HANDLE CC 128 MM  
SCREW 3.5 MM SELF-TAPPING OR M4  
MATERIAL: PP  
SURFACE: POLISHED

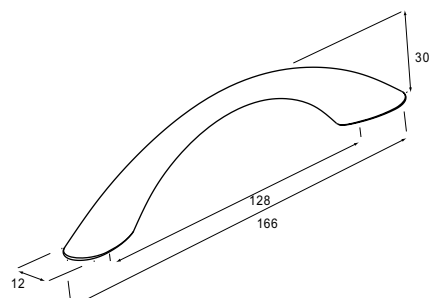

## STANDARD RANGE

**MAGNUM CC 96 MM**

**0446**

MAGNUM CC 96  
SCREW 3.5 MM SELF-TAPPING  
MATERIAL: PP  
SURFACE: POLISHED

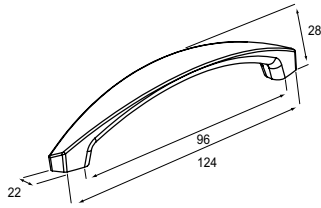

**MAGNUM CC 128 MM**

**0447**

MAGNUM CC 128  
SCREW 3.5 MM SELF-TAPPING  
MATERIAL: PP  
SURFACE: POLISHED

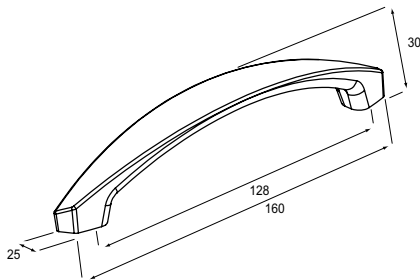

**MAGNUM CC 160 MM**

**0448**

MAGNUM CC 160  
SCREW 3.5 MM SELF-TAPPING  
MATERIAL: PP  
SURFACE POLISHED

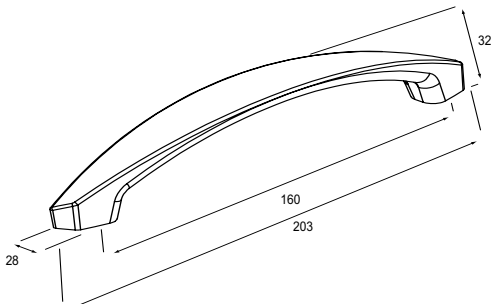

**RAMLÖSA 1 PC CC 64 MM**

**0418**

RAMLÖSA 1 PC 64 MM  
SCREW 3.5 MM SELF-TAPPING  
MATERIAL: PP  
SURFACE: SPARKLED / POLISHED

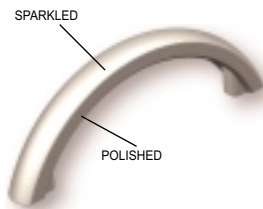
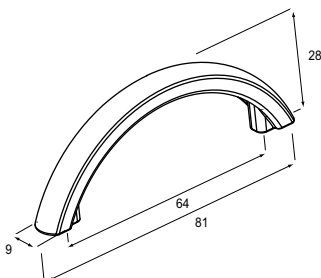

**RAMLÖSA 1 PC CC 96 MM**

**0481**

RAMLÖSA 1 PC CC 96 MM  
SCREW 3.5 MM SELF-TAPPING  
MATERIAL: PP  
SURFACE: SPARKLED / POLISHED

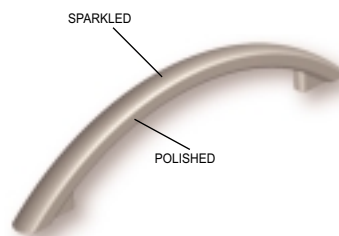
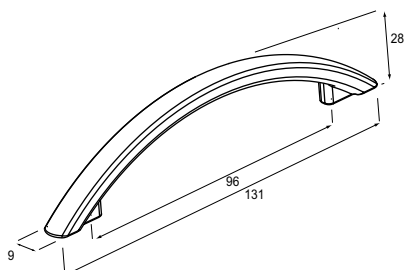

## STANDARD RANGE

0475

RAMLÖSA 1 PC CC 128 MM

RAMLÖSA 1 PC CC 128 MM  
SCREW 3.5 MM SELF-TAPPING  
MATERIAL: PP  
SURFACE: SPARKLED / POLISHED

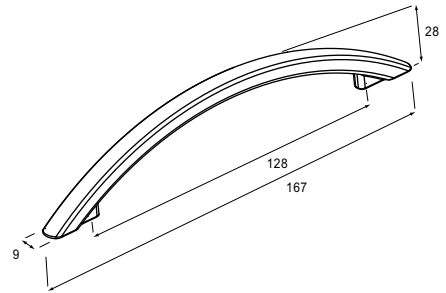
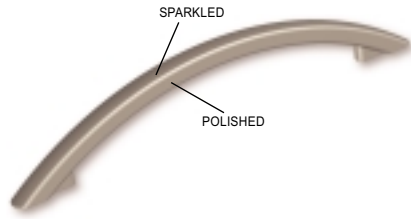

0414

RAMLÖSA 1 PC CC 64 MM

RAMLÖSA 1 PC CC 64 MM  
SCREW 3.5 MM SELF-TAPPING  
MATERIAL: PP  
SURFACE: SPARKLED / POLISHED

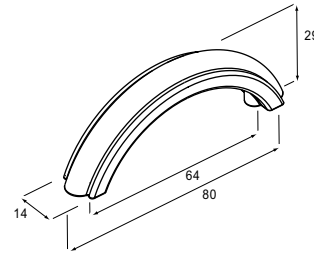

0479

RAMLÖSA 1 PC CC 96 MM

RAMLÖSA 1 PCS CC 96 MM  
SCREW 3.5 MM SELF-TAPPING  
MATERIAL: PP  
SURFACE: SPARKLED / POLISHED

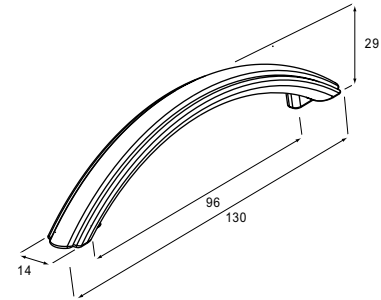
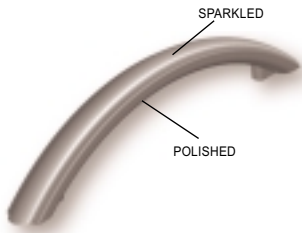

0473

RAMLÖSA 1 PC CC 128 MM

RAMLÖSA 1 PC CC 128  
SCREW 3.5 MM SELF-TAPPING  
MATERIAL: PP  
SURFACE: SPARKLED / POLISHED

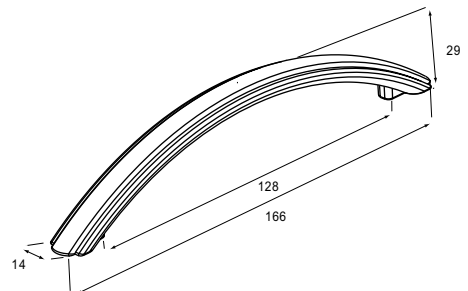
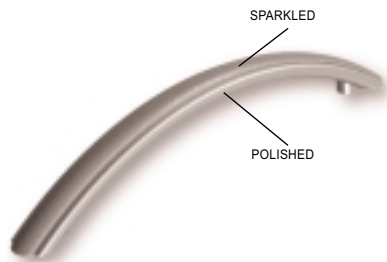

## STANDARD RANGE

### VIKTORIA CC 128 MM

0482

VIKTORIA CC 128 MM  
SCREW 3.5 MM SELF-TAPPING  
MATERIAL: PP  
SURFACE: POLISHED

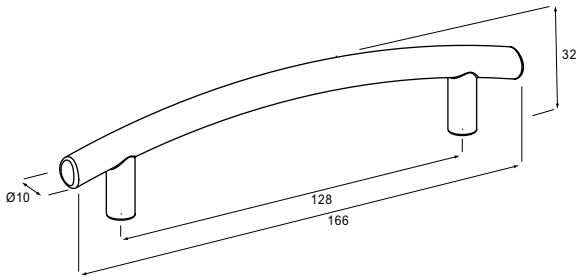

### MADELEINE CC 128 MM

0514

MADELEINE CC 128  
SCREW 3.5 MM SELF-TAPPING  
MATERIAL: PP  
SURFACE: POLISHED

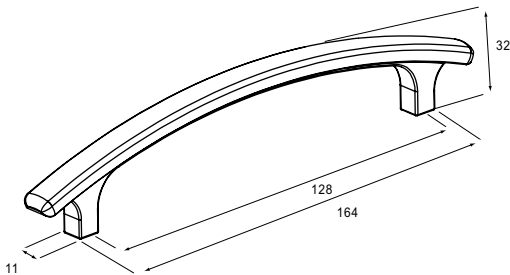

### RAMLÖSA 2 PCS CC 64 MM

0418/0417

RAMLÖSA 2 PCS CC 64  
SCREW 3.5 MM SELF-TAPPING  
MATERIAL: PP  
SURFACE: SPARKLED / POLISHED

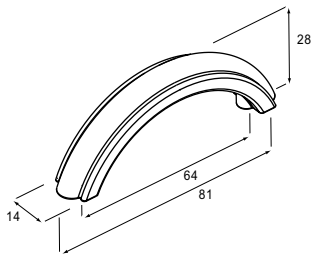

### RAMLÖSA 2 PC CC 96 MM

0481/0480

RAMLÖSA 2 PCS CC 96 MM  
SCREW 3.5 MM SELF-TAPPING  
MATERIAL: PP  
SURFACE: SPARKLED / POLISHED

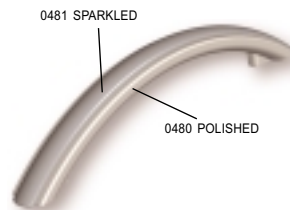
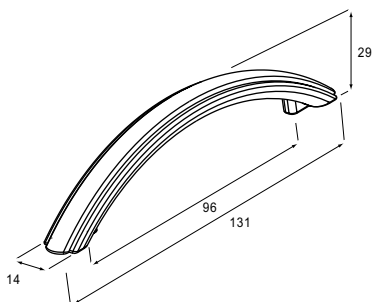

### RAMLÖSA 2 PC CC 128 MM

0475/0474

RAMLÖSA 2 PCS CC 128 MM  
SCREW 3.5 MM SELF-TAPPING  
MATERIAL: PP  
SURFACE: SPARKLED / POLISHED

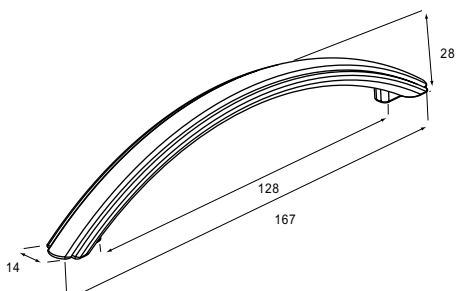

## STANDARD RANGE

**0420**

**BOW-HANDLE CC 96 MM**

BOW-HANDLE CC 96 MM  
SCREW 3.5 MM SELF-TAPPING  
MATERIAL: PP  
SURFACE: POLISHED

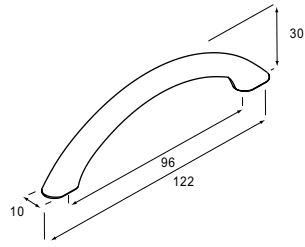

**0440**

**BOW-HANDLE CC 128 MM**

BOW-HANDLE CC 128 MM  
SCREW 3.5 MM SELF-TAPPING  
MATERIAL: PP  
SURFACE: POLISHED

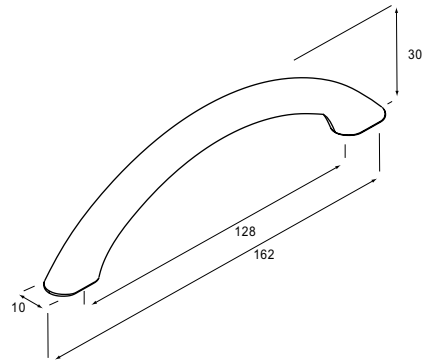

**0408**

**BOW-HANDLE CC 32 MM Ø 10 MM**

BOW-HANDLE CC 32 MM  
SCREW 3.5 MM SELF-TAPPING  
MATERIAL: PP  
SURFACE: POLISHED

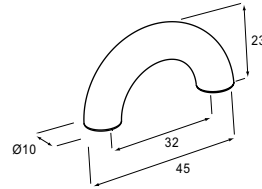

**0406**

**BOW-HANDLE CC 64 MM Ø 10 MM**

BOW-HANDLE CC 64 MM  
SCREW 3.5 MM SELF-TAPPING  
MATERIAL: PP  
SURFACE: POLISHED

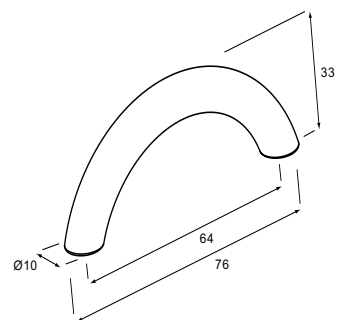

**0613/0612**

**BOW-HANDLE 2 PCS CC 64 MM**

BOW-HANDLE 2 PCS 64 MM  
SCREW 3.5 MM SELF-TAPPING  
MATERIAL: ABS  
SURFACE: POLISHED

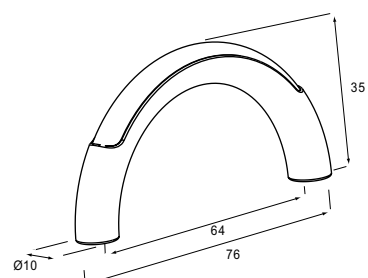

## STANDARD RANGE

### BUTTON 21X4 MM FOR 15 MM Ø D-HANDLES

0477

BUTTON 21X4 MM  
SCREW 3.5 MM SELF-TAPPING  
MATERIAL: PP  
SURFACE: POLISHED

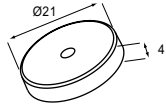

### D-HANDLE CC 96 MM Ø 15 MM

0407

D-HANDLE CC 96 MM Ø 15 MM  
SCREW 3.5 MM SELF-TAPPING  
MATERIAL: PP  
SURFACE: POLISHED

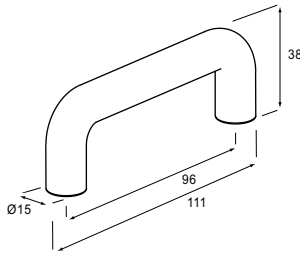

### D-HANDLE CC 128 MM Ø 15 MM

0412

D-HANDLE CC 128 MM Ø 15 MM  
SCREW 3.5 MM SELF-TAPPING  
MATERIAL: PP  
SURFACE: POLISHED

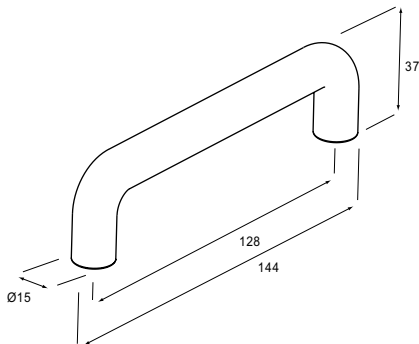

### D-HANDLE CC 128 MM Ø 15 MM

0415

D-HANDLE CC 128 MM Ø 15 MM  
SCREW 3.5 MM SELF-TAPPING  
MATERIAL: PP  
SURFACE: SPARKLED

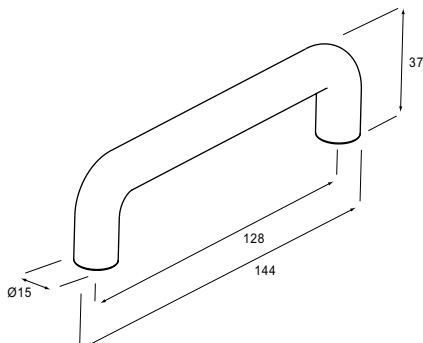

## STANDARD RANGE

**0413**

**BUTTON 15X3 MM FOR 10 MM Ø D-HANDLES**

BUTTON 15X3 MM  
SCREW 3.5 MM SELF-TAPPING  
MATERIAL: PP  
SURFACE: POLISHED

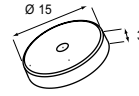

**0409**

**D-HANDLE CC 64 MM Ø 10 MM**

D-HANDLE CC 64 MM Ø 10 MM  
SCREW 3.5 MM SELF-TAPPING  
MATERIAL: PP  
SURFACE: POLISHED

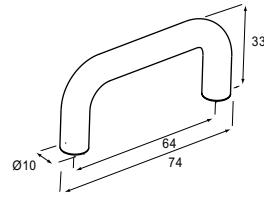

**0427**

**D-HANDLE CC 96 MM Ø 10 MM**

D-HANDLE CC 96 MM Ø 10 MM  
SCREW 3.5 MM SELF-TAPPING  
MATERIAL: PP  
SURFACE: POLISHED

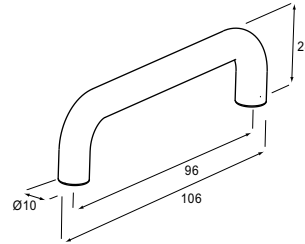

**0410**

**D-HANDLE CC 96 MM Ø 10 MM**

D-HANDLE CC 96 MM Ø 10 MM  
SCREW 3.5 MM SELF-TAPPING  
MATERIAL: PP  
SURFACE: POLISHED

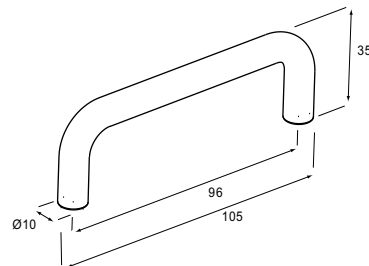

**0411**

**D-HANDLE CC 128 MM Ø 10 MM**

D-HANDLE CC 128 MM Ø 10 MM  
SCREW 3.5 MM SELF-TAPPING  
MATERIAL: PP  
SURFACE: POLISHED

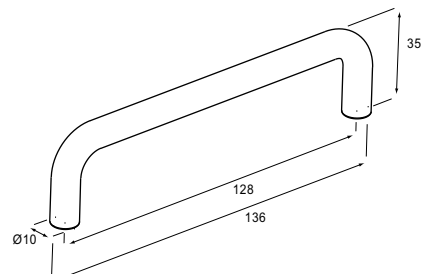

STANDARD RANGE

**TWIST CC 96 MM**

**0492**

TWIST CC 96 MM  
SCREW 3.5 MM SELF-TAPPING  
MATERIAL: PP

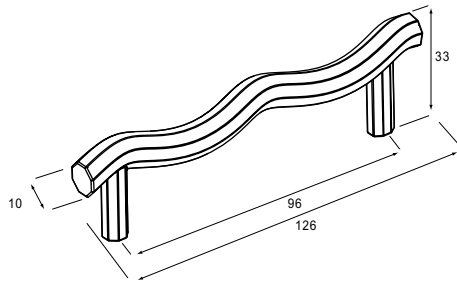

**D-HANDLE 2 PCS CC 96 MM**

**0425/0426**

D-HANDLE 2 PCS CC 96 MM  
SCREW 3.5 MM SELF-TAPPING  
MATERIAL: PP  
SURFACE: POLISHED

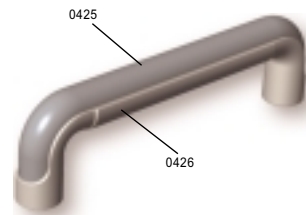
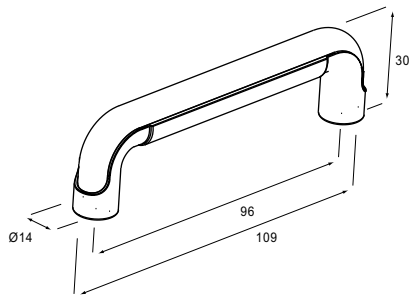

**PRISMA 2 PCS 96 MM**

**0460/0461**

PRISMA 2 PCS CC 96 MM  
SCREW 3.5 MM SELF-TAPPING  
MATERIAL: ABS  
SURFACE: POLISHED

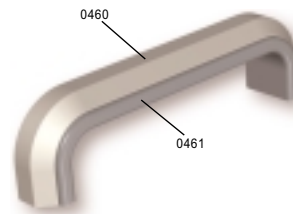
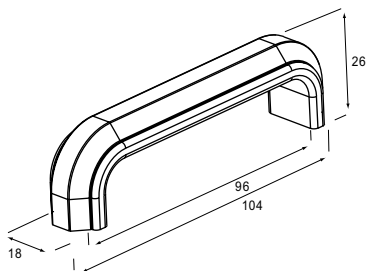

**REGAL 2 PCS 64 MM**

**0608/0609**

REGAL 2 PCS CC 64 MM  
SCREW 3.5 MM SELF-TAPPING  
MATERIAL: ABS  
SURFACE: POLISHED

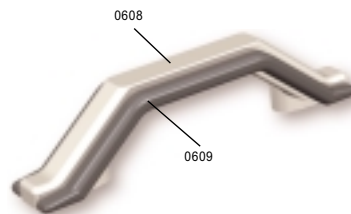
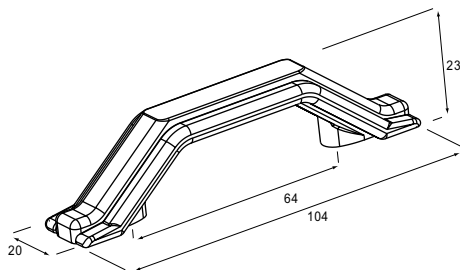

## STANDARD RANGE

**0441**

**MUSCHEL CC 32 MM**

MUSCHEL CC 32 MM  
SCREW 3.0 MM SELF-TAPPING DIN  
7981F (RXK)  
MATERIAL: ABS  
SURFACE: SPARKLED

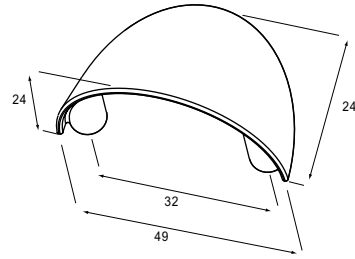

**0617**

**GERONA 1 PC CC 96 MM**

GERONA 1 PC CC 96 MM  
SCREW 3.5 MM SELF-TAPPING  
MATERIAL: ABS  
SURFACE: POLISHED

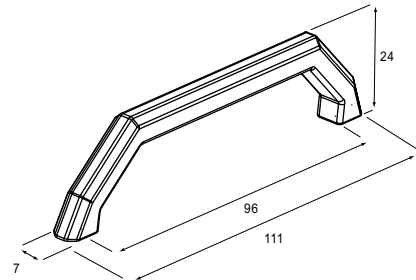

**0616/0617**

**GERONA 2 PCS CC 96 MM**

GERONA 2 PCS CC 96 MM  
SCREW 3.5 MM SELF-TAPPING  
MATERIAL: PP / ABS  
SURFACE: POLISHED

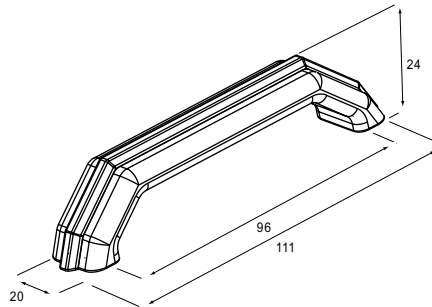
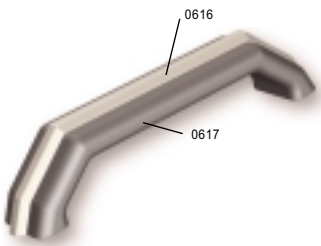

**0615**

**FLORENCE CC 64 MM**

FLORENCE CC 64 MM  
SCREW 3.5 MM SELF-TAPPING  
MATERIAL: ABS  
SURFACE: POLISHED

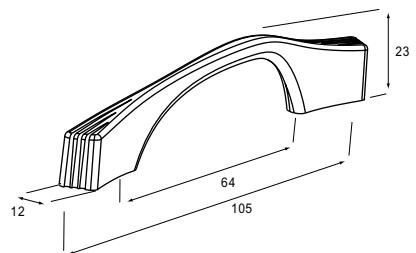

## STANDARD RANGE

### KNOB UFO

0421

KNOB UFO CC 16 MM  
SCREW 3.5 MM SELF-TAPPING  
MATERIAL: PP  
SURFACE: SPARKLED / POLISHED

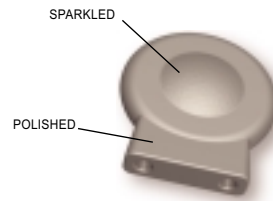
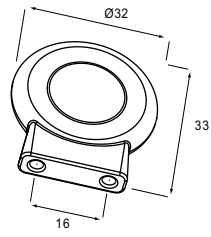

### TRIANGLE CC 32/64 MM

0416

TRIANGLE CC 32/64 MM  
SCREW 3.5 MM SELF-TAPPING  
MATERIAL: ABS  
SURFACE: POLISHED

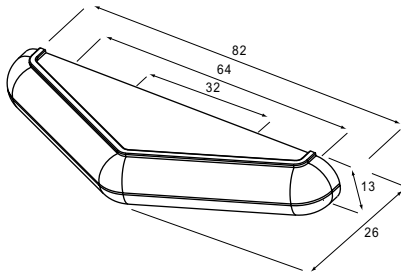

### MONTAN CC 32 MM

0490

MONTAN CC 32 MM  
SCREW 3.5 MM SELF-TAPPING  
MATERIAL: ABS  
SURFACE: POLISHED

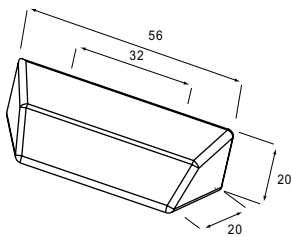

### MARINO CC 32 MM

0618

MARINO CC 32 MM  
SCREW 3.5 MM SELF-TAPPING  
MATERIAL: PP  
SURFACE: POLISHED

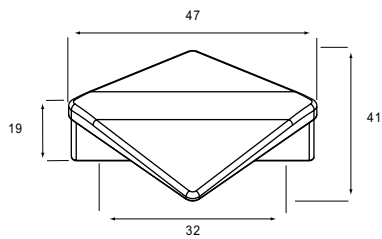

### "M" CC 32 MM

0491

"M" CC 32 MM  
SCREW 3.5 MM SELF-TAPPING  
MATERIAL: PP  
SURFACE: PATTERN DECOR

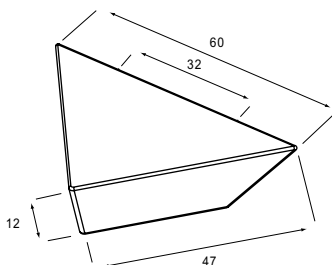

## STANDARD RANGE

0442/0444

### FURNITURE SHELL

FURNITURE SHELL Ø 50/35 MM  
MATERIAL: PP  
SURFACE: POLISHED

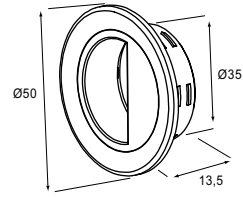

0443/0444

### FURNITURE SHELL

FURNITURE SHELL Ø 44/35 MM  
MATERIAL: PP  
SURFACE: POLISHED

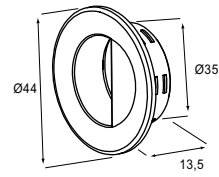

0449/0444

### FURNITURE SHELL

FURNITURE SHELL Ø 44/35 MM  
MATERIAL: PP  
SURFACE: SPARKLED / POLISHED

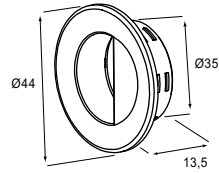
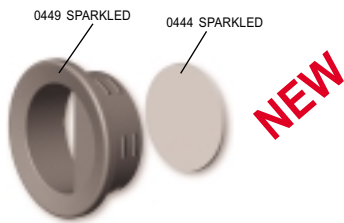

STANDARD RANGE

**KNOB ESKIL**

**0484**

*KNOB ESKIL  
SCREW 3.5 MM SELF-TAPPING  
MATERIAL: PP  
SURFACE: SPARKLED / POLISHED*

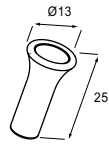

**KNOB ESKIL**

**0485**

*KNOB ESKIL  
SCREW 3.5 MM SELF-TAPPING  
MATERIAL: PP  
SURFACE: SPARKLED / POLISHED*



**KNOB ESKIL**

**0476**

*KNOB ESKIL  
SCREW 3.5 MM SELF-TAPPING  
MATERIAL: PP  
SURFACE: SPARKLED / POLISHED*

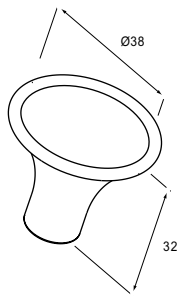

**KNOB SOFIERO**

**0463**

*KNOB SOFIERO  
SCREW 4.0 MM SELF-TAPPING  
MATERIAL: PP  
SURFACE: SPARKLED*

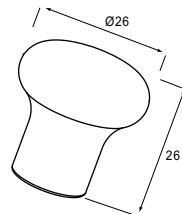

**KNOB SOFIERO**

**0472**

*KNOB SOFIERO  
SCREW 3.5 MM SELF-TAPPING  
MATERIAL: PP  
SURFACE: SPARKLED*

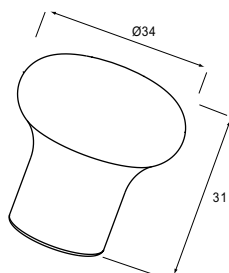

## STANDARD RANGE

0486

KNOB TWIST

KNOB TWIST  
SCREW 3.5 MM SELF-TAPPING  
MATERIAL: PP  
SURFACE: POLISHED

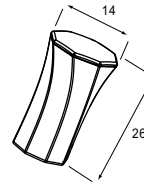

0487

KNOB TWIST

KNOB TWIST  
SCREW 3.5 MM SELF-TAPPING  
MATERIAL: PP  
SURFACE: POLISHED

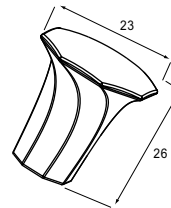

0488

KNOB TWIST

KNOB TWIST  
SCREW 3.5 MM SELF-TAPPING  
MATERIAL: PP  
SURFACE: POLISHED

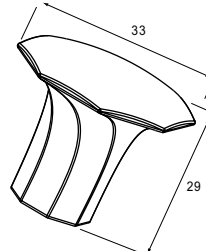

## STANDARD RANGE

### KNOB BEVEL

0424

KNOB BEVEL  
SCREW 3.5 MM SELF-TAPPING  
MATERIAL: PP  
SURFACE: POLISHED

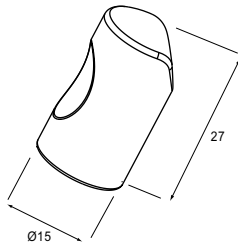

### KNOB GROVES

0422

KNOB GROVES  
SCREW 3.5 MM SELF-TAPPING  
MATERIAL: PP  
SURFACE: POLISHED

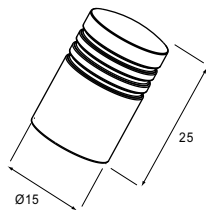

### KNOB EXTEL

0433

KNOB EXTEL  
SCREW 3.5 MM SELF-TAPPING  
MATERIAL: PP  
SURFACE: SPARKLED

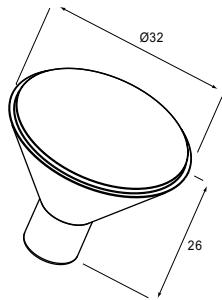

### KNOB GLOBE

0404

KNOB GLOBE  
SCREW 3.5 MM SELF-TAPPING  
MATERIAL: PP  
SURFACE: POLISHED

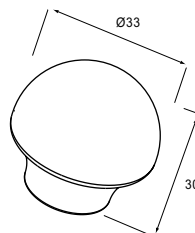

## STANDARD RANGE

0403

### KNOB SOLID

KNOB SOLID  
SCREW 3.5 MM SELF-TAPPING  
MATERIAL: PP  
SURFACE: POLISHED

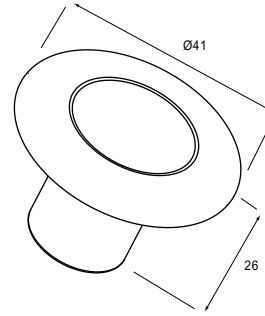

0401

### KNOB CLASSIC

KNOB CLASSIC  
SCREW 3.5 MM SELF-TAPPING  
MATERIAL: PP  
SURFACE: POLISHED

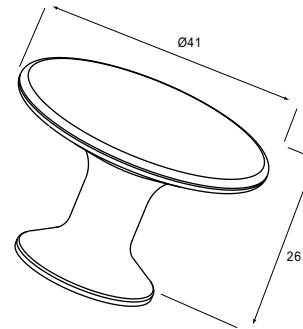

0431/0430

### KNOB MUSCROOM 2 PCS

KNOB MUSCROOM 2 PCS  
SCREW 3.5 MM SELF-TAPPING  
MATERIAL: PP  
SURFACE: POLISHED

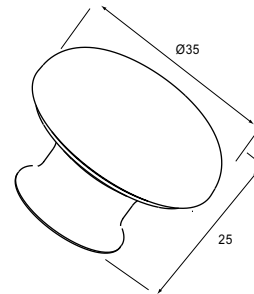

0620/0619

### KNOB YORK 2 PCS

KNOB YORK 2 PCS  
SCREW 3.5 MM SELF-TAPPING  
MATERIAL: PP  
SURFACE: POLISHED

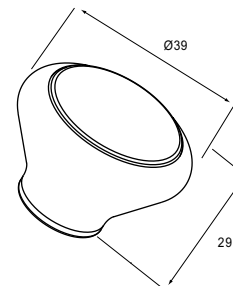
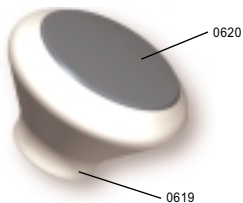

0621/0619

### KNOB YORK 2 PCS

KNOB YORK 2 PCS  
SCREW 3.5 MM SELF-TAPPING  
MATERIAL: PP  
SURFACE: POLISHED

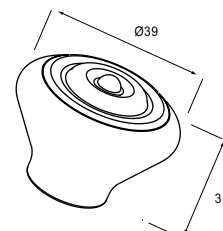
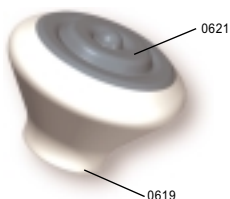

## STANDARD RANGE

### WARDROBE RAIL BRACKET CC 32 MM

0362

WARDROBE RAIL BRACKET CC 32 MM  
MATERIAL: PP  
SURFACE: SPARKLED

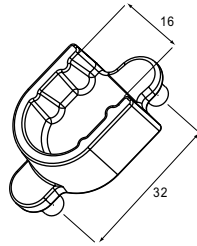

### CHILD SAFETY HOOK

0504

CHILD SAFETY HOOK  
MATERIAL: PA6, NATURE  
SURFACE: SPARKLED

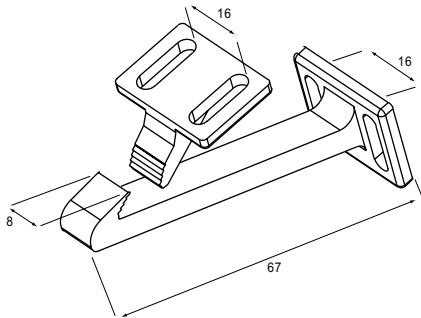

### CLUTCH-JAW

0471

CLUTCH-JAW  
MATERIAL: PA6, BLACK  
SURFACE: SPARKLED

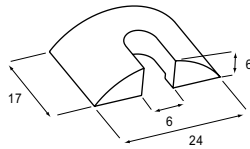

## STANDARD RANGE

0516

### FIXING-PLATE

FIXING-PLATE  
METAL INSERT M8 L= 8 MM  
MATERIAL: PP  
SURFACE: SPARKLED

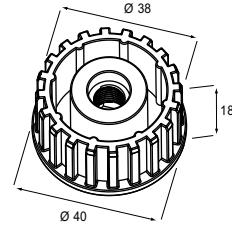

0515

### BASE-PLATE

BASE-PLATE  
SCREW 3,5 MM SELF-TAPPING  
MATERIAL: ABS  
SURFACE: SPARKLED

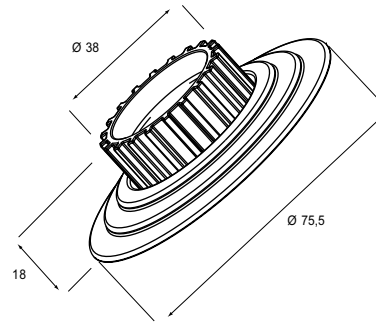
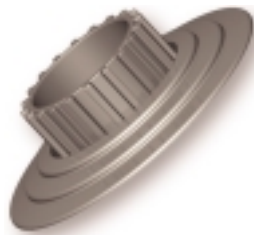

0508

### FURNITURE FOOT

FURNITURE-FOOT  
SCREW 3,5 MM SELF-TAPPING  
MATERIAL: SB  
SURFACE: SPARKLED

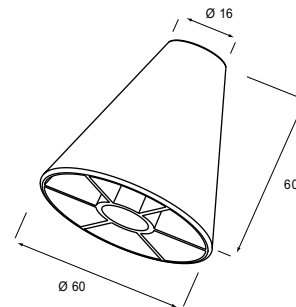

0509

### FURNITURE FOOT

FURNITURE-FOOT  
SCREW 3,5 MM SELF-TAPPING  
MATERIAL: SB  
SURFACE: SPARKLED

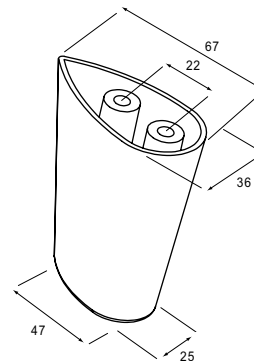

0720

### FURNITURE FOOT

FURNITURE-FOOT  
SCREW 3,5 MM SELF-TAPPING  
MATERIAL: PP  
SURFACE: POLISHED

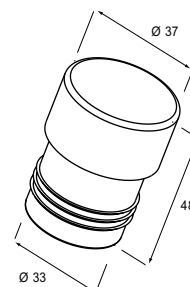

# ADJUSTABLE FOOT DROOP

**NEW**

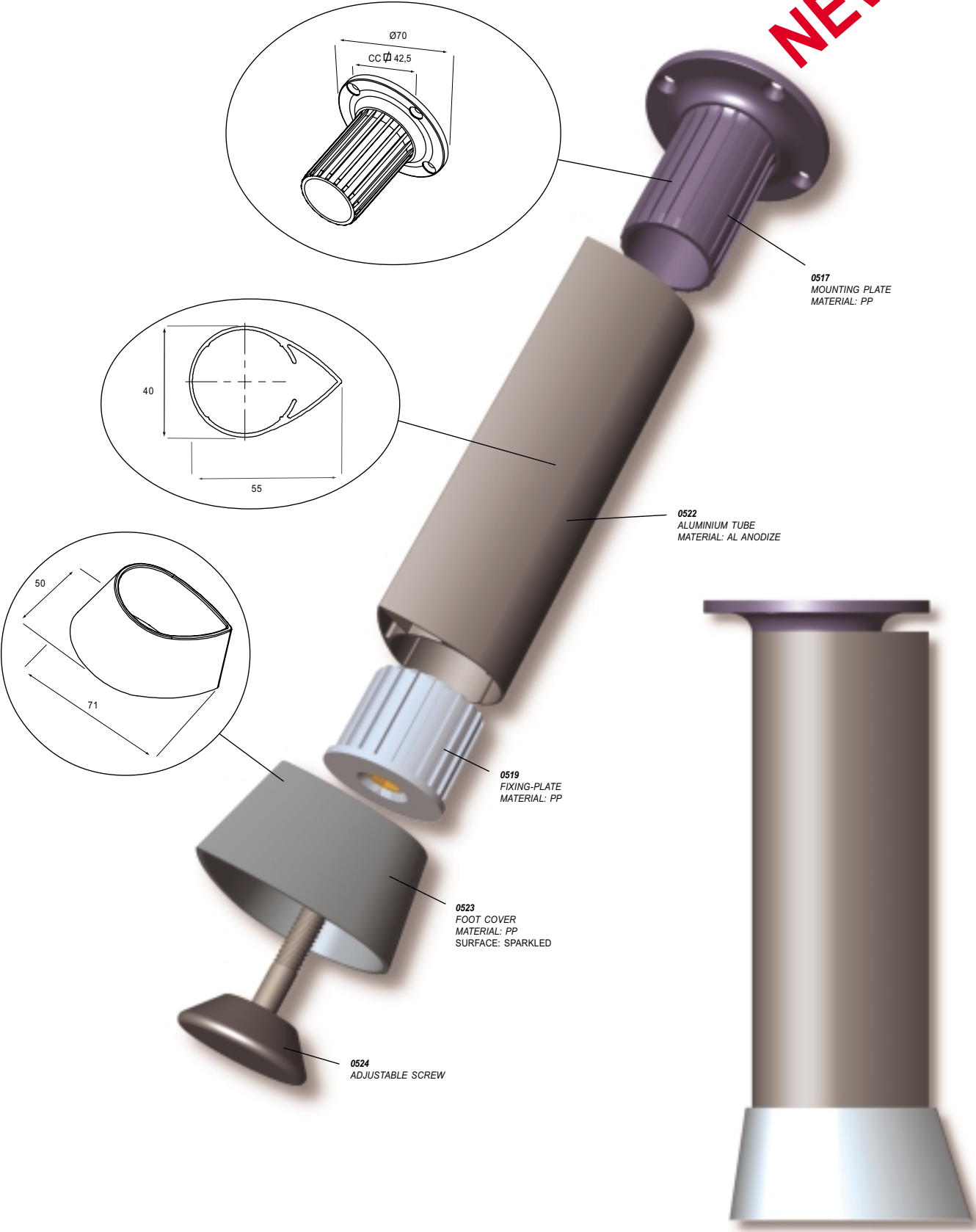

# ADJUSTABLE FOOT ROUND

**NEW**

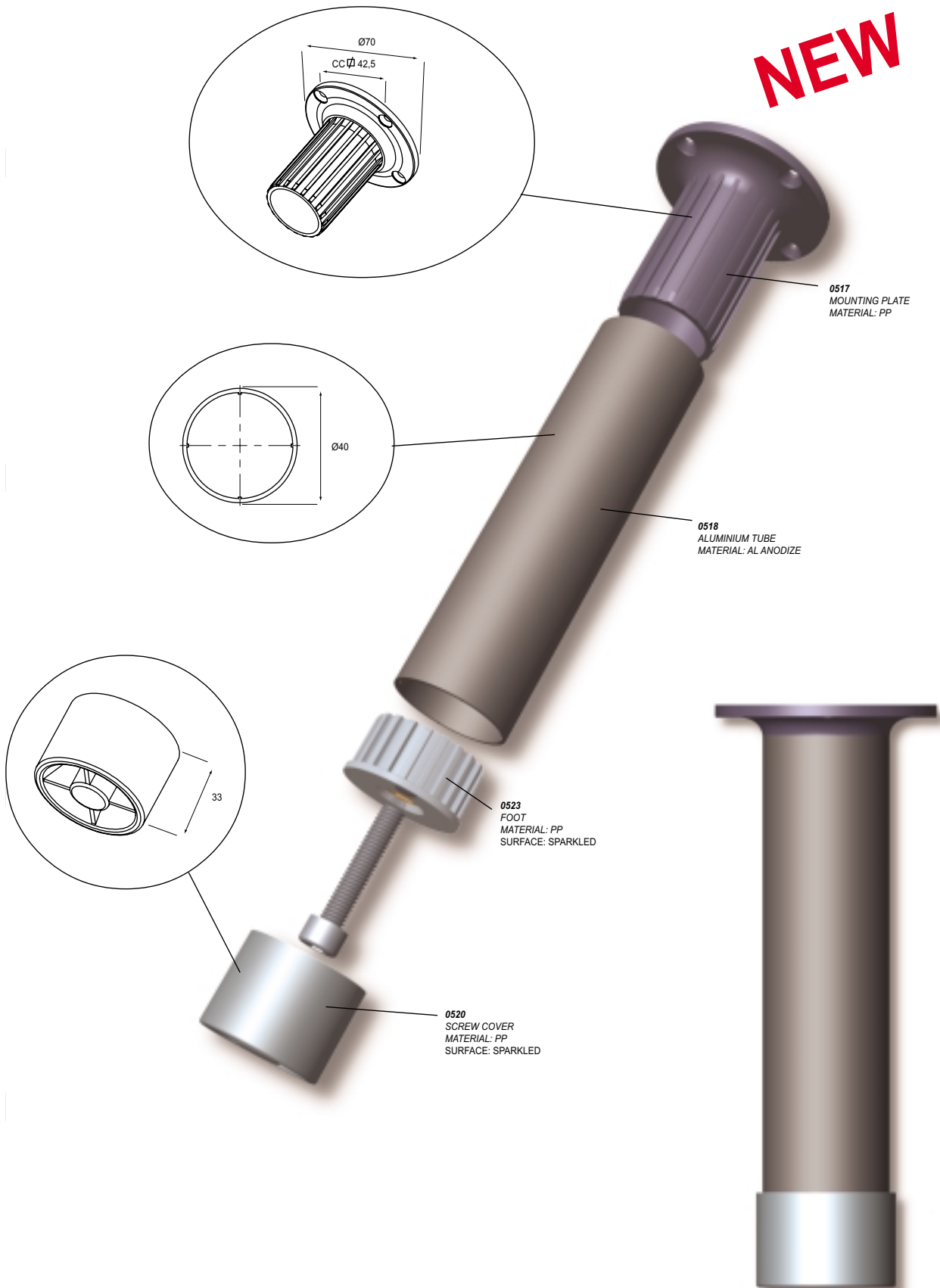

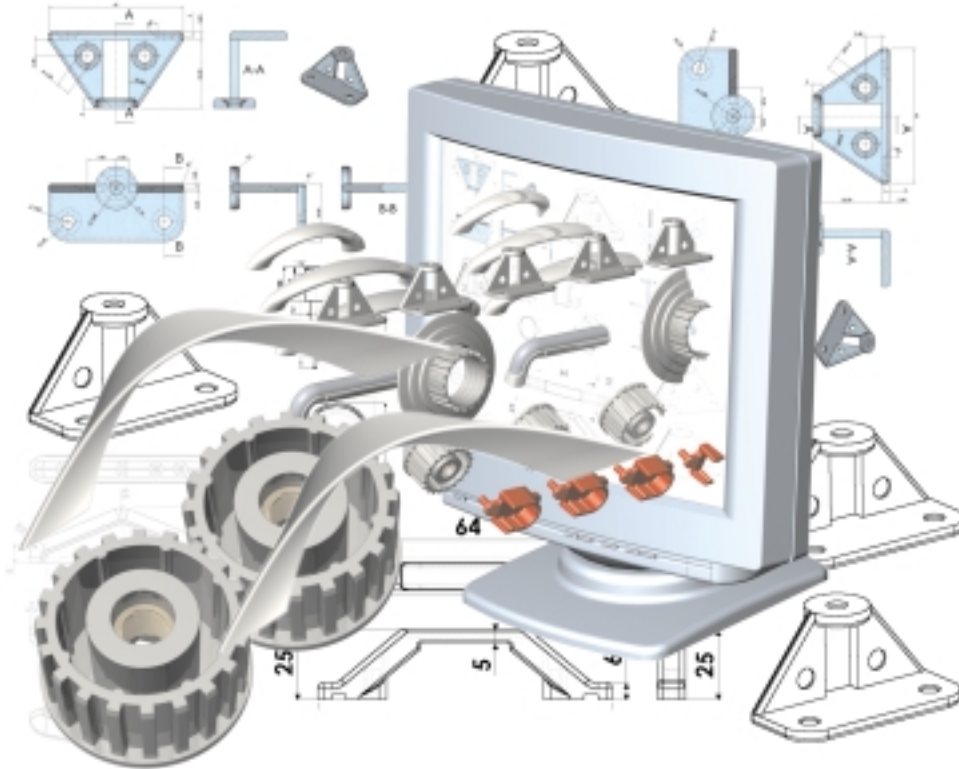

**CALL IN AND SEE US!  
WE CAN HELP YOU!  
GET A GRIP ON THINGS!**

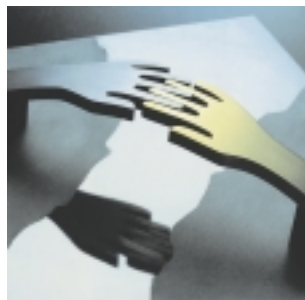

**CERTIFIED COMPANY  
SS-EN ISO 14001  
SS-EN ISO 9002**

# ALL UNDER ONE ROOF!



Sundplast has all the necessary resources under one roof. The company manufactures all types of injection moulding tools using modern CAD CAM technology. Sundplast is certified according to the quality standard ISO 9002, environmental standard ISO 14001 and are a member of The Swedish Plastic industry Association.

Over 20 injection moulding machines up to 2500 kn. guarantee rapid delivery in a wide range. We also function as subcontractors on a wide range of assignments, including quality control, wrapping, marking and ultrasonic welding

**CALL IN AND SEE US!  
WE CAN HELP YOU!  
GET A GRIP ON THINGS!**



[www.sundplast.com](http://www.sundplast.com)

Rev. 01

